

4FA021301

## MAIN UNIT - 1 stereo channel P3271 - P3272

- 1 - Audio output level indicator LED.
- 2 - Audio output level adjustment.
- 3 - Signal input connector (left).
- 4 - Signal input connector (right).
- 5 - Telecontrolled socket.
- 6 - Power switch.
- 7 - LOCAL/REMOTE telecontrol selector switch.
- 8 - Led indicator showing activation of telecontrol (green)
- 9 - Led indicator showing connection to mains.
- 10 - Connection strips to sound system installation.
- 11 - Connection strip to mains.
- 12 - Mono/Stereo switch
- 13 - Grille
- 14 - Frame (delivered separately)

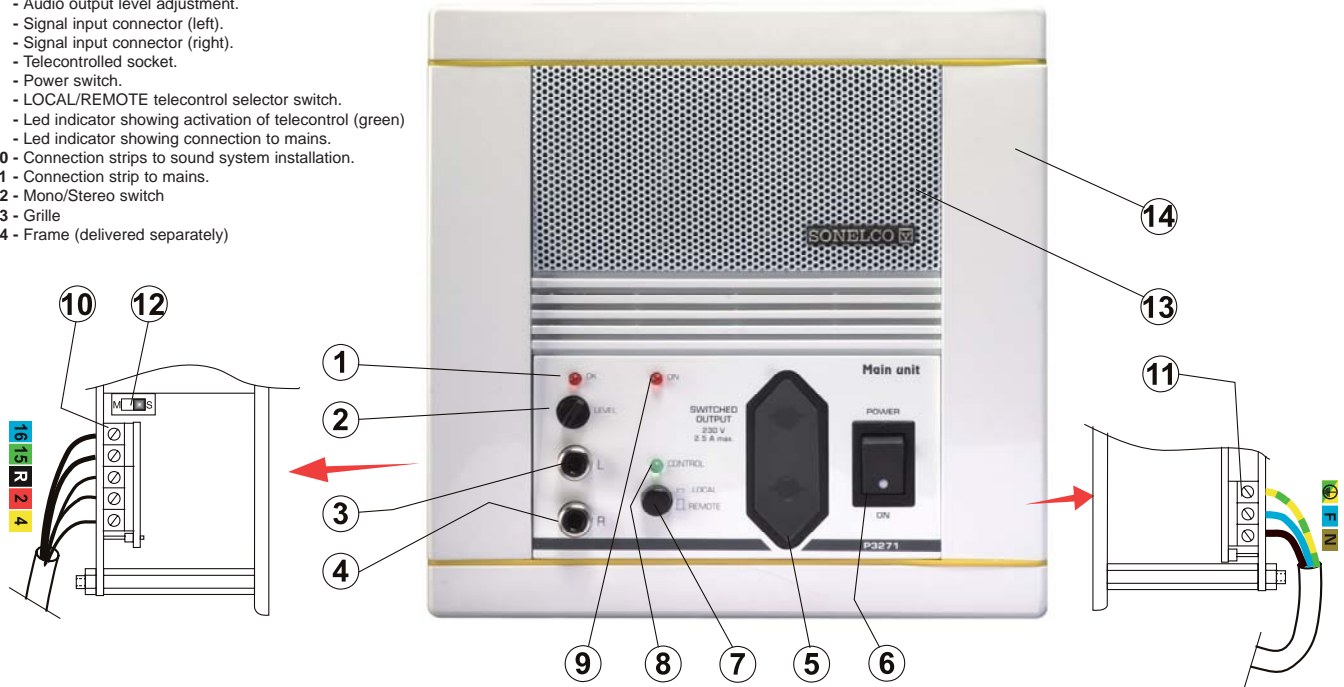

### DESCRIPTION

Unit with 1 stereo channel. It has manual audio level adjustment. With optimum output level indicator LED.

### GENERAL CHARACTERISTICS

- Audio inputs with CINCH connectors (3,4).
- Internal Mono/Stereo switch (12)
- Built-in 60 VA supply source, supplying 16 V DC with electronic filter for general supply of the system (terminal 2).
- Mains input voltage: 230V AC (50/60 Hz) P3271  
115V AC (50/60 Hz) P3272
- Electronic protection against short-circuits and overloads in the supply.
- Telecontrol (with selector switch 7 in REMOTE position). When any of the system controls are activated, socket (5) automatically connects supplying 220V to the sound source. When all the controls of the system are switched off this socket disconnects automatically, switching off the sound source, with the subsequent energy saving.
- Local control (with selector switch 7 in LOCAL position). To switch on the outer sound source manually, regardless of the state of the system controls.
- Two-pin power switch (6) to totally disconnect the system. LED indicating operation of the unit (9).
- Incorpora un fusible de protección de la entrada de red y base telecontrolada, y una protección de la salida de alimentación en baja tensión para la instalación (además de la protección electrónica).
- Rejilla aireación con ventilador interno bajo ruido y con conexión automática
- All the components used for connection to the mains are officially approved, complying with the strictest safety regulations.
- Internal fan with automatic activation.

### CONNECTION

The main unit will be installed in a P9002 flush-mount box or in a P9026 surface-mount box, preferably next to the sound source.

The connection to the 220/230V mains will be done with at least 1 sq.mm. section wires and double insulation. For safety reasons the earth connection must also be connected.

**NOTE:** It is advisable for the cables of the electricity supply mains to be as far away as possible from the unit circuit.

The connection to the distribution line can be done with wires, P9910 ó P9940 (in the case of paging or intercom) for the supply and the music channels. The other wires can be used if required for any of the auxiliary functions.

#### TERMINALS:

- F- Phase (P3271 - 220/230 V AC) (P3272 - 115/125 V AC)
- N- Neutral (P3271 - 220/230 V AC) (P3272 - 115/125 V AC)
- ⊕- Earth (protection conductor)
- 2- Positive - voltage output 16 V DC nominal/4 A maximum
- 4- Negative - Supply and signal ground.
- 15- Audio output - Channel 1 Left - 3 V RMS max.
- 16- Audio output - Channel 1 Right - 3 V RMS max.
- R- Auxiliary terminal for telecontrol.



**IMPORTANT NOTE:** Before connecting this unit to the electricity supply mains, the power switch of that system must be disconnected to make sure the connection is made with the correct safety guarantees. Under no circumstances must the unit be handled outside its flush box, connected to the alternating current network. Make sure that you have made the earth connection correctly.

**CONNECTION TO MAINS:** Insert the mains and the earth wires into the terminal strip (11) (to the right of the mains switch), through the holes situated on the rear circuit protector of the unit, and tighten the screws of the strip. Make sure they are well-tight and that no wire thread is outside the holes.

**CONNECTION TO THE SOUND LINE:** Connect the wires of the sound line to the strip (10), passing the wires through the groove of the circuit protector, with care not to mistake the order. Make sure the screws are tightened correctly.

**CONNECTION TO THE SOUND EQUIPMENT:** Connect the mains plug to the telecontrolled mains socket (5). Connect the audio output of the equipment to the CINCH connectors (3,4) on the front of the unit. To do this use a stereo connection wire (not supplied with the unit) with CINCH connectors on one end and with the connectors used in the music equipment.

**NOTE:** Terminal R permits the remote operation of the telecontrol. It is used when two or more units are installed together. By interconnecting their R terminals, if the telecontrol of one of the units trips that of the other trips at the same time.

Likewise this terminal can be used for the remote trip of the telecontrol. If terminal R is connected to ground (terminal 4) the telecontrol trips the same as if we place selector switch 7 in the LOCAL position.

#### OPERATION:

Once the unit has been installed in its housing (flush box or surface) screw the base plate to the box and fit the trims with the colour strips you wish (not supplied with the unit). Then connect the power switch to supply current to the unit.

Operate the power switch (6) and see if the ON indicator (9) has come on. Led 8 must not come on or if it does, it must be on GREEN (indicating telecontrol activated).

#### OPERATION INCIDENTS

**A.- IF LED (9) DOES NOT LIGHT UP WHEN THE POWER SWITCH IS ACTIVATED**, check that there is voltage, that the mains wires are correctly connected or if fuse (12, situated under the upper lid) has blown. If this fuse has blown replace it with another one of the same characteristics and value.

**B.- IF THE SOUND IN THE SYSTEM CANNOT BE HEARD CORRECTLY**, turn the level control (2) to the right until level Led (1) blinks on and off to the sound of the music.

**C. - IF THE SOUND IN THE SYSTEM IS DISTORTED**, turn level control (2) to the left until level Led (1) blinks on and off to the sound of the music. If Led (1) is too bright or practically does not go off this means that the audio output is distorted.

**D. - IF THE ON LED (9) TURNS ON AND OFF**, check that the ventilation grille is not obstructed, and that the installed load is not higher than allowed (4 A)

## TECHNICAL CHARACTERISTICS

#### AUDIO:

- 1 stereo channel
- Input impedance: 30K Ohm.
- Maximum sensitivity: 250 mV
- Recommended input level: 250mV - 2V (máx. 25V)
- Frequency response: 10Hz. - 25KHz. (-3dB)
- THD: < 0.1%
- S/N ratio: > 70 dB
- Crosstalk between channel L and R: < 65 dB
- Output: 3 V RMS maximum.
- Protection against short-circuits in the audio lines.

#### SUPPLY:

Mains input:

- Operation: 180-264 V AC / 50-60Hz - **P3271**
- 92-132 V AC / 50-60Hz - **P3272**

- Maximum power: 60 VA
- Voutput: adjusted between 16 V  $\pm$  5%
- Ioutput: 4 A
- Electronic protection against short-circuits and overload in the output. Internal protection fuse of the supply source.

#### TELECONTROL:

- Telecontrolled socket 220/230 V / 2.5 A máx.
- Telecontrol by voltage
- LED indicator (green) of activation of telecontrol
- LOCAL activation selector switch of the telecontrol.
- Fusible interno 2.5A proteccion para limitación corriente base de red

#### GENERALES:

- Maximum dimensions : 142 x 146 x 50 mm.
- Minimum flush space: 120 x 120 x 40 mm.
- Weight: 480 grs.

## INSTALLATION EXAMPLE

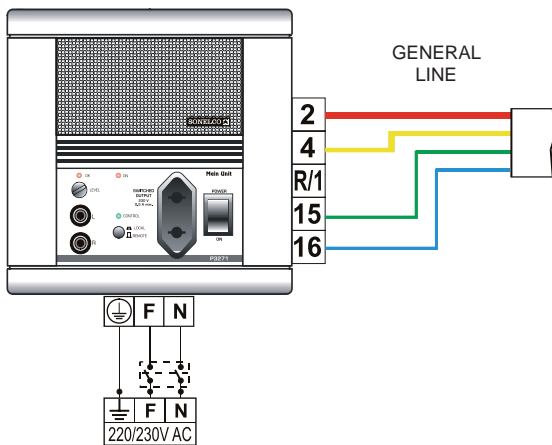

## INSTALLATION RECOMMENDATIONS

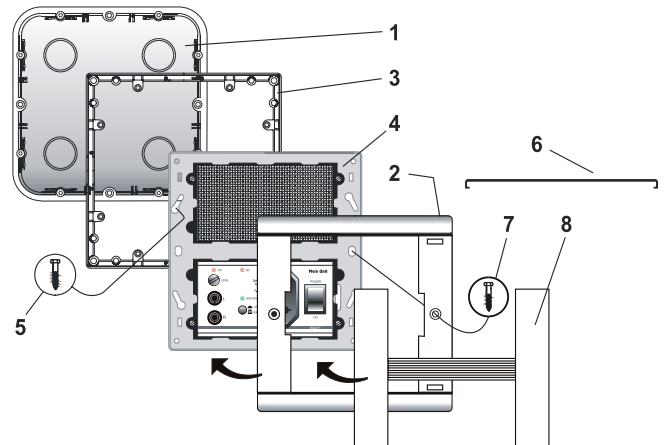

KM9211-01 (WHITE) KM9211-02 (CHARCOAL) KM9211-03 (TWO-TONE)

#### DOUBLE FRONT FRAME + SUPPLEMENT FOR "SONELCO" BOXES:

During the installation of main units and power supply units, it is advisable to fit the supplement (3). By doing this an extra 12 mm. bottom is achieved on the flushmount box (1), which makes assembly easier and provides greater ventilation.

To correctly assemble the supplement:

- Remove the four screws (5) from the flushmount box (1)
- Pass the wires through the supplement (3)
- Connect and screw the module (4) together with the supplement (3) to the flushmount box (1)
- Place the frame (2) on the base plate (4) and press
- Place the side screws (7)
- Put the covers (8) on the sides (2)
- Optionally, trims can be fitted (6)



## INSTALLATION RECOMMENDATIONS

In Sonelco's General Diagrams, you will find connection diagrams and cable sections recommended for the audio installation.

Do not install this product in damp places, near heat sources or in potentially explosive atmospheres.

The connection to the mains, installation, cable section and wiring will be done in accordance with the directives and specific regulations of each country.

**Sonelco recommends installing a specific on/off switch for the sound system (See installation example).**

**Sonelco declines any responsibility which might be derived from the incorrect use of the product or installation not in accordance with that recommended.**