

On the front piece we can see the following points:

1.-Level adjustment, with switch. 2.- Operation indicator Led. 3.- Power peak indicator Led. 4.- Temperature excess indicator Led. 5.- Breakdown indicator Led in the unit. 6.- Unit lock. 7.- DC protection fuses. 8.- AC protection fuse. 9.- Line / diffuser connection terminal strip. 10.- 220 v AC connection terminal strip. 11.- 100 v line transformer connection. 12.- 100 v line transformer Adjustment. 14.- Power circuit. 15.- Temperature sensor.

NOTE: The electronic protection adjustments (13) are factory adjusted, and must not be handled under any circumstances

DESCRIPTION

Mono 120 W / 100 V power unit. Self-protected electronically against shortcircuits, signal peaks, excess temperature and breakdown of the unit itself. 230 V AC mains supply. Automatic operation with possibility of manual disconnection. Level adjustment potentiometer. Operation and unit status light indicators. Wall fitted. Frequency response: 4 Hz - 11 KHz

OPERATION

- The unit possesses an initial connection delay of about 2 seconds to prevent the connection noise in the loudspeakers. Once this time has elapsed, if the working conditions are normal, LED 1 will light up and the unit is working normally.
- If LED 3 lights up, and the sound in the loudspeakers cuts off, this means that there are sound peaks of more than 120W which could damage the loudspeakers of your installation. Reduce the level with adjuster 1.
- If LED 4 lights up, and the sound in the loudspeakers cuts off, this means that the temperature of the radiator is excessive. The unit must be disconnected and some time must pass for it to cool down. This situation may be due to working at maximum level for too long a period of time, or, due to having connected a line transformer unit with a total load of more than 120 w to its outlet.
- If LED 5 lights up, the unit will not work (LED 2 out) and it is likely that there is an internal breakdown. Follow the steps below:
 - 1.- Disconnect the unit by turning adjuster (1) to the left until a click is heard.
 - 2.- Wait at least 30 seconds.
 - 3.- Connect the unit again with the control (1).
 - 4.- If the problem persists, disconnect the unit again.
 - 5.- Open the door (using key 6) and check that the three fuses which are in the printed circuit are correct. If not substitute them for fuses of the same type and value.
 - 6.- If the problem continues, warn the Technical Service, of the breakdown of this unit.

NOTE: During the normal operation, the radiator can reach high temperature, so it is recommended for it to be installed in a ventilated area and with free space of at least 10 cms. around it.

CONNECTION

TERMINALS

- Terminal 3** - Input + 16 V. Connect to general line 2
- Terminal 4** - Ground. Connect to line 4
- Terminal 5** - Audio input. Connect to general line 5
- Terminal A** - Audio output (+). Connect to + 100 V line
- Terminal M** - Ground. Connect to - of the 100 V line
- Terminal 03** - Control output - Connect to terminal 3 of other slave unit (public-address diagram 2 and 14)
- Terminal AV, TP** - Connect to main unit control 4052 (public-address diagrams 2 and 14)
- Terminal F,N,T** - Mains input 230 V 50/60 Hz.

TECHNICAL CHARACTERISTICS

The power unit Mod. 4644 has the following characteristics:

- OUTLET POWER: 120 w (continuous)
- OUTLET: 100 v line
- RESPONSE: 4 Hz-11 Khz.
- DISTORTION: < 0.2%
- Active protection against short-circuits.
- Active protection against excess temperature.
- Active protection against excessive power peaks.
- Active protection against unit breakdown.
- Initial connection delay: < 2 sec.
- DIMENSIONS: 250x300x180mm.
- WEIGHT: 9.500grs.

CONNECTION 100 V

The difference with unit Mod. 4643 is that it has a line transformer and therefore its outlet is at a constant voltage of 100 v. In this way the connection of horn speaker is made easy when due to the amount a 4 ohm impedance cannot be obtained.

The connection in line of 100 v is always done parallelly. The power of each horn speaker is calculated by dividing the total power of the unit by the number of horn speakers we wish to connect. The horn speakers must incorporate a 100 v line transformer, suitable for the power of the same.

For example, the connection of 6 horn speakers to a 120 w unit would be done:

$$\text{power per horn speake} = \frac{120w}{6} = 20w$$

Therefore, each horn speaker must support 20w, and be provided with a 100v line transformer for. Its recommendable for the horn speakers to be able to support a power, at least 25% greater, than that which they are really going to support (for example in this case we must use horn speakers of 25 w.

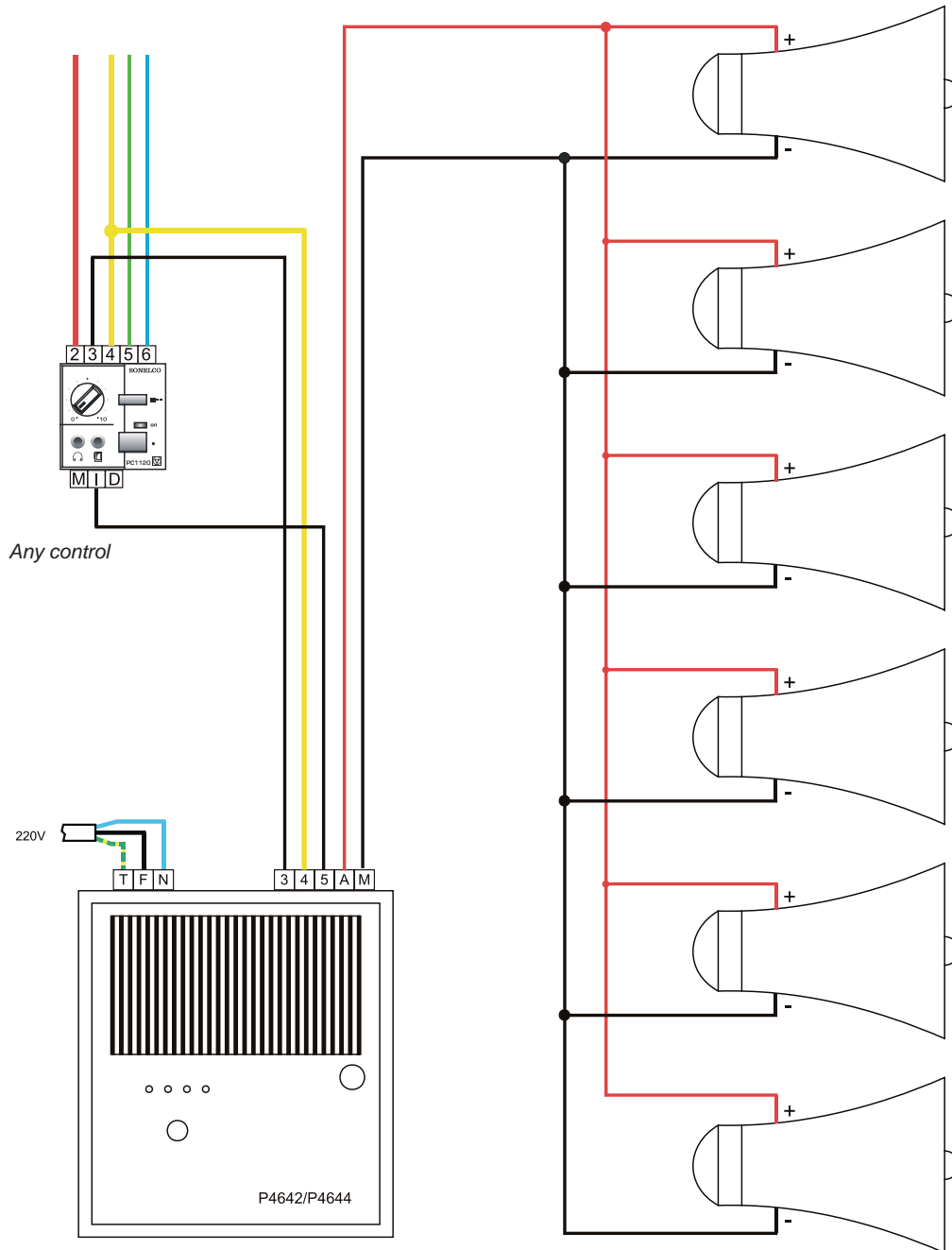

20w per horn speaker
6 x horn speakers.